



EVRM-NA
EVRM-6NA

Safety solenoid valves for gas
Manual reset - Normally open
DN10 ... DN300

EVRM-NA

EVRM-6NA

Safety solenoid valves for gas

Manual reset - Normally open

Contents

Description	2
Features	2
Functioning and application	3
Technical specifications	4
Gas flow chart (pressure drop)	6
Ordering information	8
Special versions and optionals	8
Design, installation and servicing	9
Standards and approvals	10

Description

The EVRM-NA /6NA type valve is a manual reset safety valve that is normally open. The closing function is electrically activated. This type of device, connected to one or more gas leakage detectors, safety thermostat or alarm signals for the presence of carbon monoxide, is suitable to perform locking operations on the gas line.

Features

The valves are made of aluminum alloy die-cast (or hot-pressed brass for OT versions), with a wide range for inlet/outlet connections from DN10 up to DN 300.

Pipe connections meet group 2, according to EN161 requirements.

Suitable for use with air and non-aggressive gases included in the 1, 2 and 3 families (EN 437). Special versions for aggressive gases (Biogas).



The whole range can be provided in Ex-proof execution, for use in Zones 2 and 22, according to 94/9/EC Directive (ATEX).

Two range of operating pressure: low pressure (0...600 mbar) and medium pressure (0...6 bar).

The kind of valves are normally not powered allowing a remarkable energy saving.

An incorporated fine mesh filter protects the valve seat and disc as well as downstream components and prevents dirty contamination (except brass models).

Provided with G1/4 pressure gauge on two sides in the inlet chamber (except brass models), to connect manometers, pressure switches, leakage tester or other gas equipments. Flanged models are provided with gauges also in the outlet chamber.

The encapsulated coil is provided with ISO 4400 plug and suitable cable gland to avoid water and dirty contamination, allowing a safe outdoor installation.

All components are designed to withstand any mechanical, chemical and thermal condition occurring during typical service. Effective impregnation and surface treatments have been used to improve mechanical sturdiness, sealing and resistance to corrosion of the components.

Valves are 100% tested by computerized testing machineries and are fully warranted.



WARNING

This control must be installed in compliance with the rules in force.

Functioning and application

The EVRM-NA /6NA type valve is a manual reset safety valve that is normally open. A manual operation is therefore necessary to open the valve and to reset the mechanism consenting to maintain this state. The powering by means of line current and/or condenser discharge, induced by the leakage detector, safety thermostat or alarm system causes driving of the mechanism and consequent closing of the gas orifice. If energizing of the sensor persists because of the presence of gas, the valve remains under power and does not allow reset. When the causes for locking have been eliminated, valve must be opened manually.

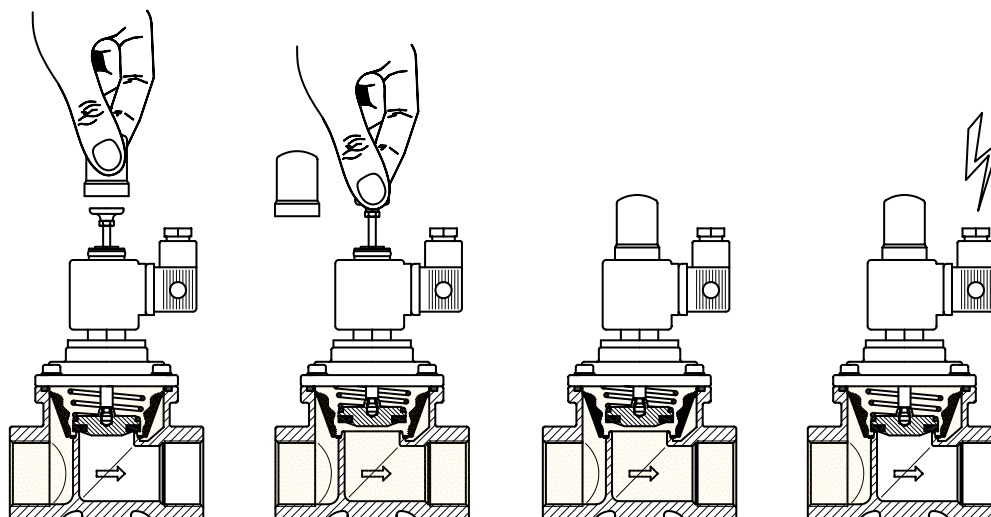

Fig.1



The models from DN125 and bigger and the 6 bar versions are provided with a dual-shutter system for pressure compensation. To open the valve pull the knob for the first step, wait for pressure compensation, and then pull the knob completely up to full resetting.

This kind of device is normally installed downstream a manual shut-off valve and upstream of the gas regulating train. Figure 2 shows a example of installation.

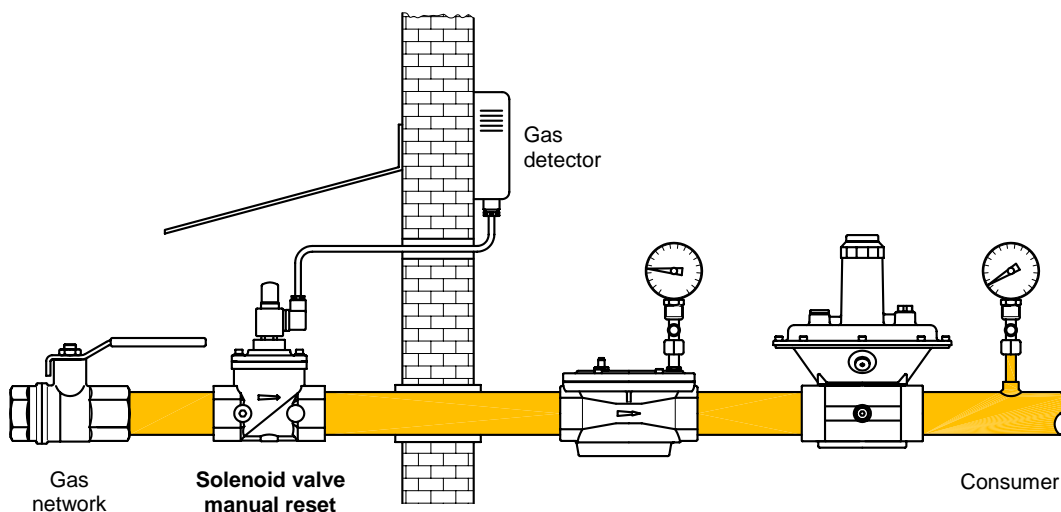

Fig.2



WARNING

Location and mode of installation must be in compliance with local rules in force.

Technical specifications

Tab. 1

Connections	Gas threaded ISO 7-1 from Rp3/8 to Rp2½ Flanged PN16 – ISO 7005 from DN40 to DN300
Voltage rating	230 VAC 50/60 Hz 110 VAC 50/60 Hz 24 VAC; 24 VDC 12 VDC
Voltage tolerance	-15% / +10%
Power consumption	see charts
Ambient temperature	-15°C / +60°C
Max. operating pressure	600 mbar (60 kPa) 6 bar (600 kPa)
Flow capacity	see charts
Closing time	< 1 second
Filter (except brass models)	600 µm, metal mesh
Protection class	IP54 (EN 60529)
Cable gland	PG 9
Coil winding insulation	Class H (200°C)
Coil thermal resistance	Class F (155°C)
Materials in contact with gas	Aluminium alloy Brass Stainless steel Plated steel Anaerobic adhesive Nitrile rubber (NBR) Polytetrafluoroethylene (PTFE)

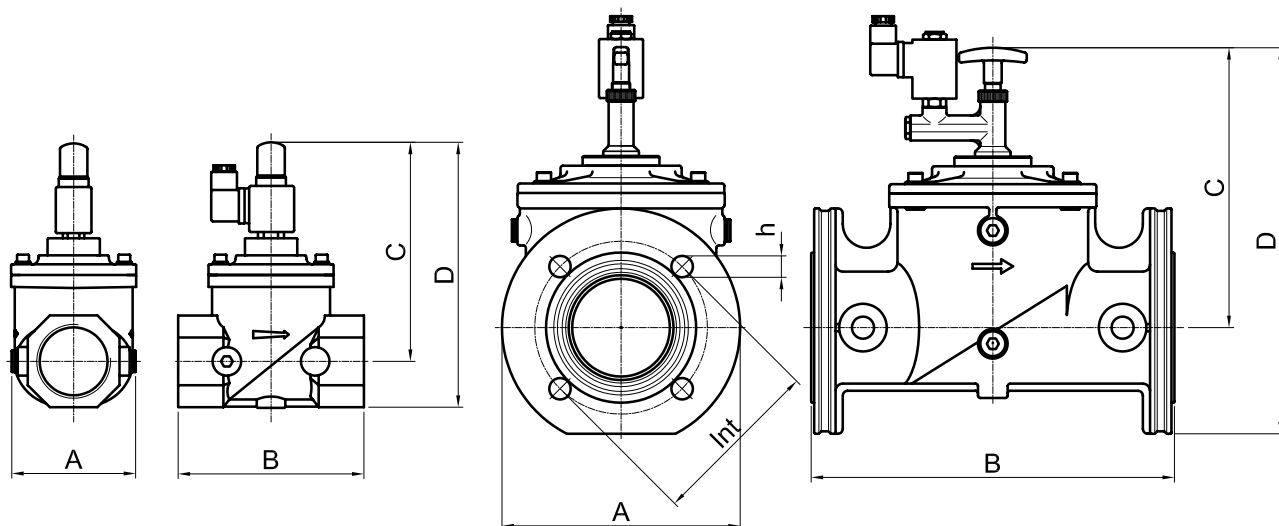

Fig.3

Tab. 2

Material and Connections		Power Consump. @230VAC [W]	Flow factor Kvs [m³/h]	Overall dimensions [mm]						Weight [Kg]
CuZn	AlSi			A	B	C	D	Int	h	
Rp 3/8		16	0,7	30	58	115	130	-	-	0,4
Rp 1/2		16	1,3	30	58	115	130	-	-	0,4
G 3/4		16	2,0	35	55	113	130	-	-	0,6
G 1		16	4,5	40	62	115	137	-	-	0,7
	Rp 3/8	16	2,9	70	77	130	148	-	-	0,6
	Rp 1/2	16	6,0	70	77	130	148	-	-	0,6
	Rp 3/4	16	9,5	85	96	138	165	-	-	0,8
	Rp 1	16	12	85	96	138	165	-	-	0,8
	Rp 1 1/4	16	20	120	153	170	203	-	-	1,6
	Rp 1 1/2	16	26	120	153	170	203	-	-	1,6
	Rp 2	16	40	106	156	175	213	-	-	1,9
	DN 40 ⁽¹⁾	16	26	150	193	170	245	110	4x18	3,3
	DN 50 ⁽¹⁾	16	40	165	196	175	257	125	4x18	3,9
	Rp 2 1/2	19	63	175	218	247 ⁽²⁾	295 ⁽²⁾	-	-	6,1
	DN 65	19	63	200	305	260 ⁽²⁾	350 ⁽²⁾	145	4x18	8,2
	DN 80	19	80	200	305	260 ⁽²⁾	350 ⁽²⁾	160	8x18	8,2
	DN 100	19	148	252	350	280 ⁽²⁾	410 ⁽²⁾	180	8x18	16
	DN 125	19	250	310	460	330 ⁽²⁾	500 ⁽²⁾	210	8x18	28
	DN 150	19	315	310	460	330 ⁽²⁾	500 ⁽²⁾	240	8x23	30
	DN 200	19	516	370	546	380 ⁽²⁾	590 ⁽²⁾	295	12x23	45
	DN 250	19	660	405	600	453 ⁽²⁾	680 ⁽²⁾	355	12x28	72
	DN 300	19	1120	460	700	500 ⁽²⁾	763 ⁽²⁾	410	12x28	99

⁽¹⁾ Optional kit ⁽²⁾ Valve open

Gas flow chart

(Pressure drop)

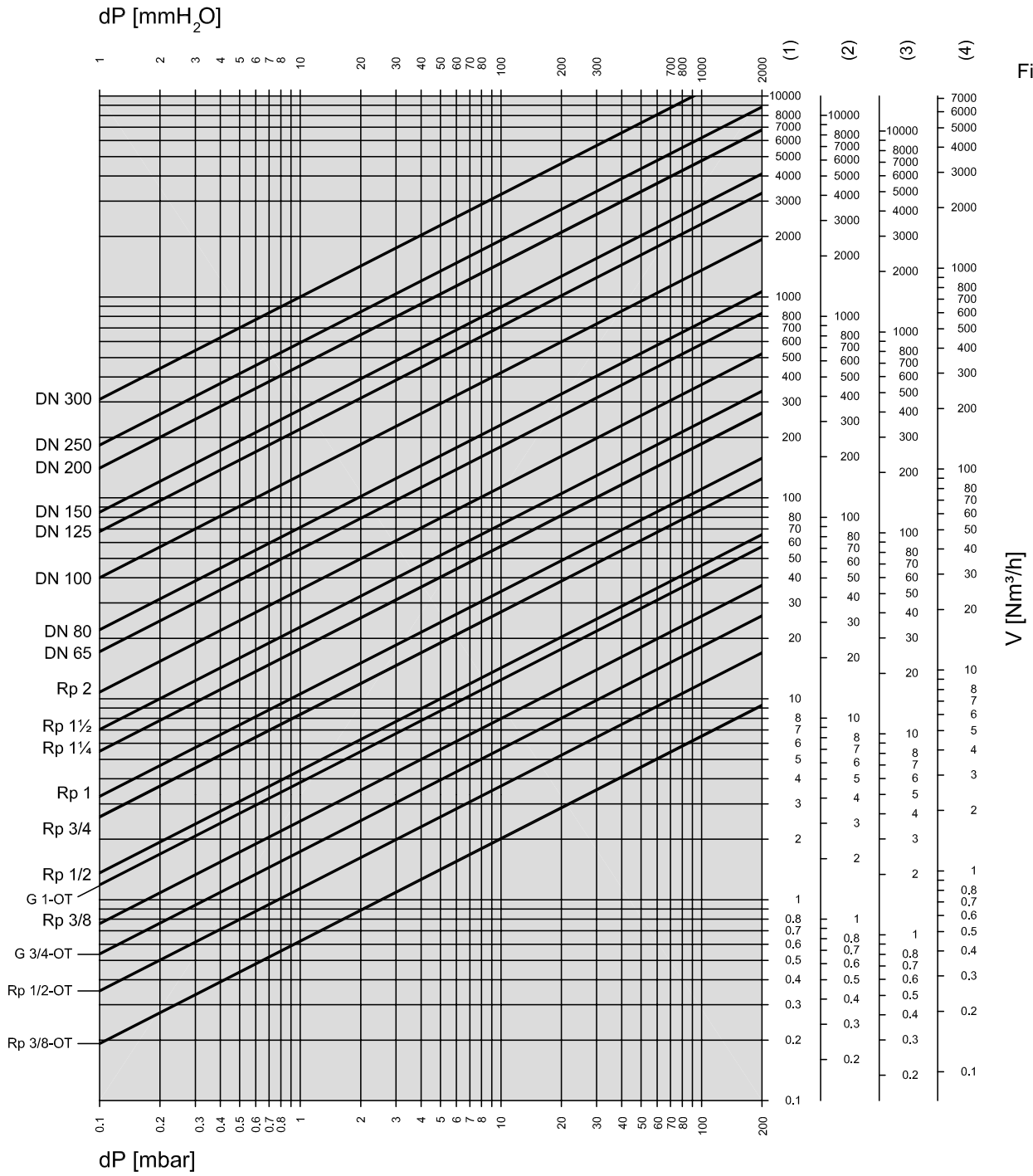

Fig. 4

Formula of conversion from air to other gases

$$V_{GAS} = k \cdot V_{AIR}$$

Tab. 3

Gas type	Specific gravity ρ [Kg/m ³]	$k = \sqrt{\frac{1.25}{\rho_{GAS}}}$
(1) Air	1,25	1,00
(2) Natural gas	0,80	1,25
(3) Town gas	0,57	1,48
(4) LPG	2,08	0,77

15°C, 1013 mbar, dry

When the flow read on the diagram is referred to operating pressure instead of standard conditions, the pressure drop Δp read on the diagram must be multiplied for the factor: (1+ relative pressure in bar)

Example:

In the 2" solenoid valve with an air flow of 80 Nm³/h there is a pressure drop $\Delta p = 5$ mbar. If we consider that 80 m³/h is the flow at 200 mbar of inlet pressure, then the pressure drop to be consider is:

$$\Delta p = 5 \times (1 + 0,2) = 6 \text{ mbar}$$

Normally, pressure drop and flow rate for the valves are read from the gas flow diagram. However, the valves can also be chosen in accordance with the characteristic "Kvs value" which is shown in table 2.

The selection of the valve requires the calculation of the Kv under the operating conditions.

Considering only subcritical pressure drops:

$$\Delta p < \frac{p_1}{2}$$

Kv can be calculated with the formula:

$$Kv = \frac{V}{514} \sqrt{\frac{\rho(t + 273)}{\Delta p \cdot p_2}}$$

where

- V = flow rate [Nm³/h]
- Kv = flow factor [m³/h]
- ρ = density [Kg/m³]
- p₁ = absolute inlet pressure [bar]
- p₂ = absolute outlet pressure [bar]
- Δp = differential pressure p₁-p₂ [bar]
- t = media temperature [°C]

To the Kv value calculated from operating conditions we add an allowance of 20%, to obtain the minimum Kvs value which the valve should have:

$$Kvs > 1,2 Kv$$



Valve must be selected considering the following:

- Pressure drops $\Delta p \leq 0,1 p_1$ are recommended and $\Delta p > p_1/2$ are always unadvisable
- Flow velocities $w \leq 15$ m/s are recommended and $w > 50$ m/s are always unadvisable.

Ordering information

Tab.4

Designation (230VAC)		Connections	Additional code for special voltages				
600 mbar	6 bar		110 VAC	24 V AC/DC ⁽²⁾	24 VDC-22W	12 VDC-12W ⁽³⁾	12 VDC-22W
EVRMNA00	EVRM6NA00	Rp 3/8 brass					
EVRMNA10	EVRM6NA10	Rp 1/2 brass					
EVRMNA20	EVRM6NA20	G 3/4 brass					
EVRMNA30	EVRM6NA30	G 1 brass					
EVRMNA0	EVRM6NA0	Rp 3/8					
EVRMNA1	EVRM6NA1	Rp 1/2					
EVRMNA2	EVRM6NA2	Rp 3/4	B	C	GW	H	HW
EVRMNA3	EVRM6NA3	Rp 1					
EVRMNA35	EVRM6NA35	Rp 1¼					
EVRMNA4	EVRM6NA4	Rp 1½					
EVRMNA6	EVRM6NA6	Rp 2					
EVRMNA4F	EVRM6NA4F	DN 40 ⁽¹⁾					
EVRMNA6F	EVRM6NA6F	DN 50 ⁽¹⁾					
			110 VAC		24 VDC	12 VDC	
EVRMNA7T	EVRM6NA7T	Rp 2½					
EVRMNA7	EVRM6NA7	DN 65					
EVRMNA8	EVRM6NA8	DN 80					
EVRMNA9	EVRM6NA9	DN 100					
EVRMNA93	EVRM6NA93	DN 125	B	–	G	H	–
EVRMNA95	EVRM6NA95	DN 150					
EVRMNA98	EVRM6NA98	DN 200					
EVRMNA910	EVRM6NA910	DN 250					
EVRMNA912	EVRM6NA912	DN 300					

⁽¹⁾ Optional kit⁽²⁾ DC operation with impulse only⁽³⁾ Provided with different mechanical parts (not interchangeable)

Special versions and optionals

The sizes 1"¼, 1"½ and 2" can be provided with G1/4 gauges also in the outlet chamber.

A closed position indicator micro-switch (CPI) can be installed. Models from DN65 to DN300 are provided with G1/8 connection on the bottom for these facilities -on request from 3/8" to 2" - (not available for brass models).

The threaded models Rp1½ and Rp2 can be provided with flanged connections using an optional kit.

The whole range can be provided with a special cable gland and Ex-proof marking for use in Zones 2 and 22, according to 94/9/EC Directive (ATEX):

category	II 3 G,D
protection mode	Ex n A II T4 X, Ex tD A 22 IP54 T135 X

J-version: the models with aluminum body from 3/8" to 6" can be supplied in special versions for aggressive gases such as biogas, they are free of non-ferrous metals in contact with gas and provided with special seals.

S-version: the models from 5" to 12" can be supplied without the inner piston for indirect acting.



The versions with inlet pressure $p_1 \leq 6$ bar (600 kPa) may be order inserting the digit "6" in to the designation.

Different voltage than 230V may be order adding to the standard designation the additional code shown above. Other optionals must be order with their ordering code.

Example: EVRM6NA3.**B** for a valve with Rp1 connections, 110VAC, 6 bar



Manufacturer reserves the right to update or make technical changes without prior notice.

Design, installation and servicing

To assure a proper and safe operation, as well as a long service life of the valve, consider the following recommendations during the design of the system where the valve will be installed:



- ✓ Ensure that all the features of your system comply with the specifications of the valve (gas type, operating pressure, flow rate, ambient temperature, electrical voltage, etc.).
- ✓ Valve may be mounted with coil in horizontal or vertical position, not upside down.
- ✓ In the event of vertical pipe, the flow direction should be from bottom to top.
- ✓ After removing the end caps make sure no foreign body will enter into the valve during handling or installation (e.g. swarf or excessive sealing agent).
- ✓ A gas filter should be always installed upstream the valve.
- ✓ Ensure that installing area is protected from rain and water splashes or drops.
- ✓ Never install the valve close to walls or other equipments.
- ✓ Perform leak and functional tests after mounting (max. testing pressure 1,5 Pmax).
- ✓ Check proper operation at least once a year (most often for aggressive gases).
- ✓ Due to seals aging, to ensure safe operation, we recommend the valve replacement after 10 years from the date of manufacture stamped on the product.
- ✓ This control must be installed in compliance with the rules in force.
- ✓ Make sure all works are performed by qualified technicians only and in compliance with local and national codes.
- ✓ To prevent product damage and dangerous situations, read carefully the instructions supplied with the product before use.

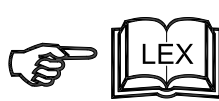

Standards and approvals

The valve design meets current European approval requirements regarding safety shut-off functions on gaseous fuels.

These products conform with the Pressure Equipment Directive (97/23/EC) and the certification has been issued by the notified body:



C.S.I. Spa
Viale Lombardia 20
I-20021 Bollate (MI)



The following standards/technical specifications have been fulfilled:

- ATEX (94/9/EC) when shown upon the product
- Electromagnetic Compatibility (2004/108/EC)
- Low Voltage Directive (2006/95/EC)
- RoHS II (2011/65/UE)

The valves comply with the Technical Regulation 753 of Russian Federation concerning the security of machinery and equipment and the certification has been issued by the Body

«INTERCERT» Ltd
Str. Profsoyuznaya, 93 A, of. 423
RU-117279 Moscow



Certificate No.: C-IT.AB86.B.04357

Quality Management System is certified according to UNI EN ISO 9001 and the monitoring is carried out by the notified body:

Kiwa Gastec Italia Spa.
Via Treviso, 32/34
I- 31020 San Vendemiano (TV)



Elektrogas is a brand name of:

Elettromeccanica Delta S.p.A.
Via Trieste 132
31030 Arcade (TV) - ITALY
tel +39 0422 874068
fax +39 0422 874048
www.elektrogas.com
www.delta-elektrogas.com
info@delta-elektrogas.com

Copyright © 2013
All rights reserved